

WORK AREA

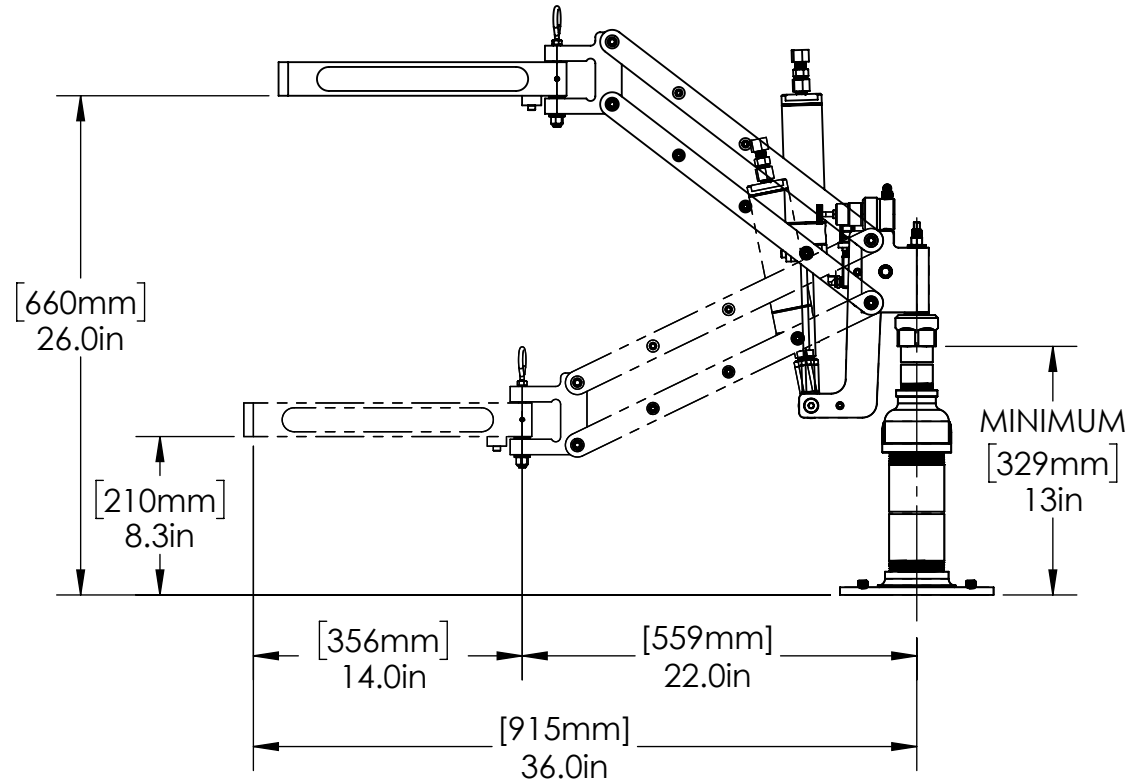
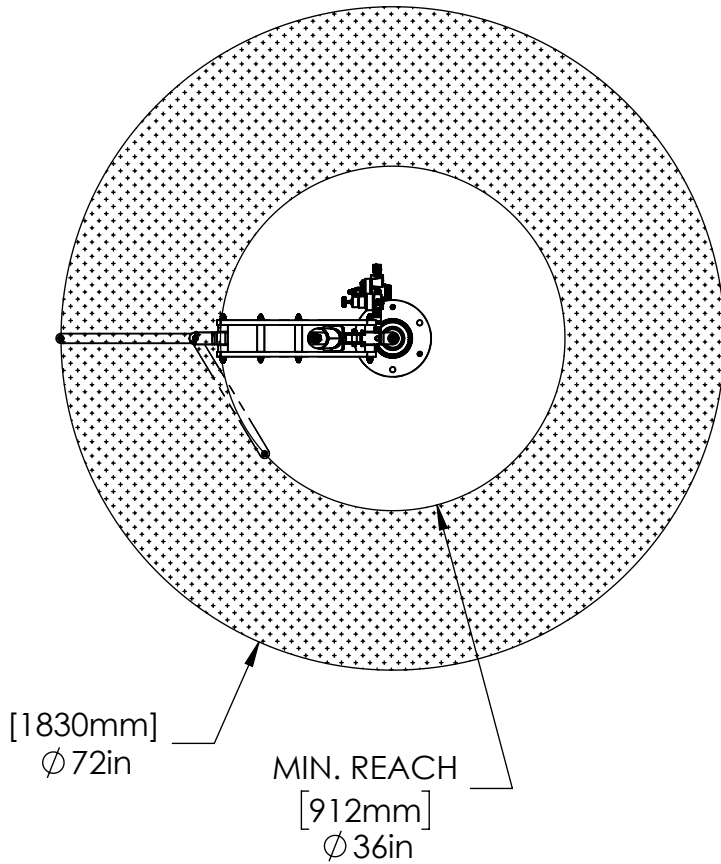

MODEL#: EL1025-N

Extra Heavy Duty Arm with our highest weight capacity has thick Parallels with cross ties for even more rigidity and a larger diameter Shoulder Pin and Bearings than the 815 frame. Includes B250 Extra Heavy Duty Base Kit.

MAX TORQUE (VERT): 1,100 in-lbs (125 Nm)

MAX TORQUE (HORZ): 600 in-lbs (68 Nm)

MAX. TOOLING WEIGHT: 25 lbs (11.4 kg)

COPYRIGHT © 2018 ERGONOMIC TOOL ARMS, LLC

[www.toolarms.com](http://www.toolarms.com)

**ETA**  
Ergonomic Tool Arms, LLC

**Model # B250  
HEAVY DUTY  
BASE**

