

SEE PAGE 2 FOR
TOOL HOLDER DETAILS

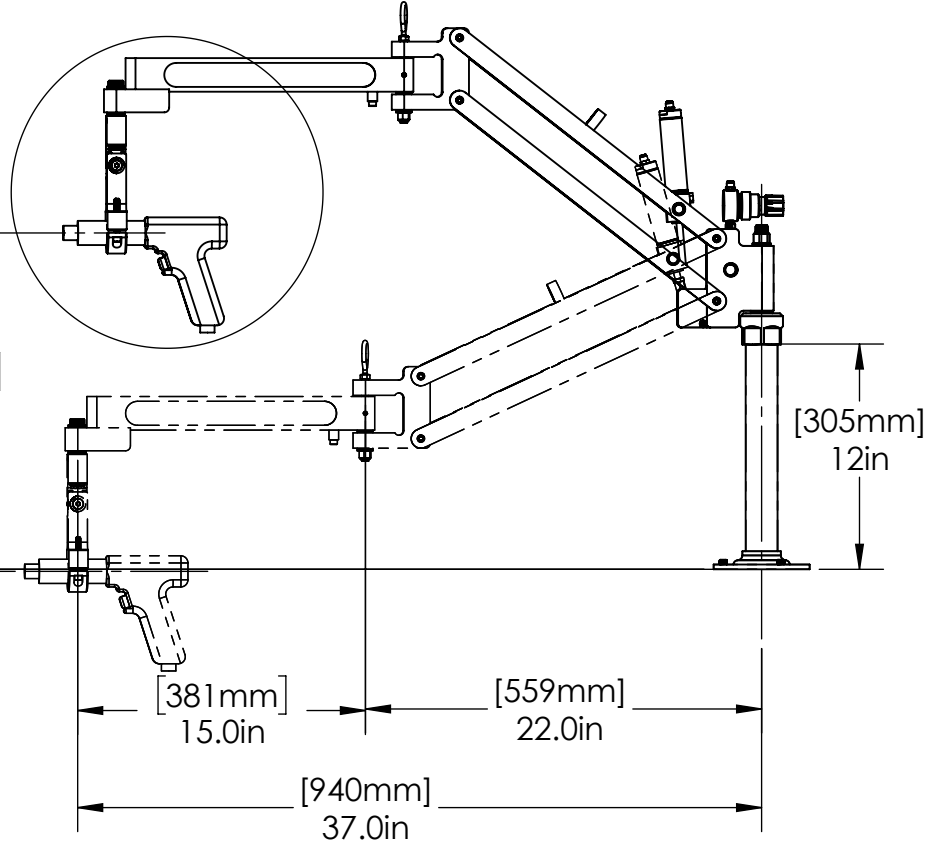

WORK AREA

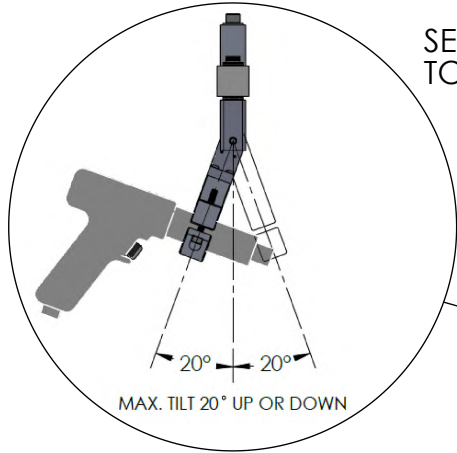
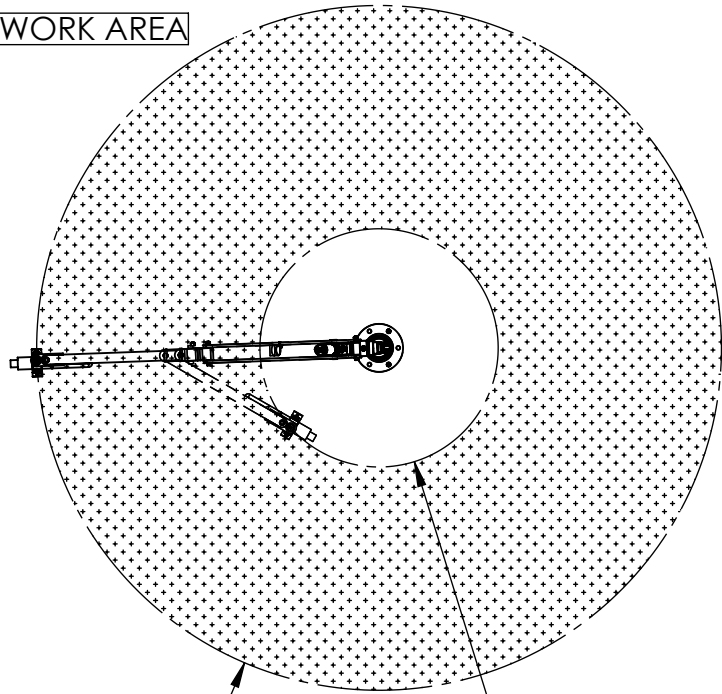

[1880mm]
Ø 74

MIN. REACH
[630mm]
Ø 25in

www.toolarms.com



MODEL#: EL506-PT

TOOL HOLDER INCLUDED, PT-TH

For HORIZONTAL Fastening with customer's Electric In-line or Pistol Tool. Allows 20° degrees tilting.

MAX TORQUE: 275 in-lbs (31 N-m)

MAX. TOOLING WEIGHT: 4.8 LBS (2.16 KG)

COPYRIGHT © 2018 ERGONOMIC TOOL ARMS, LLC

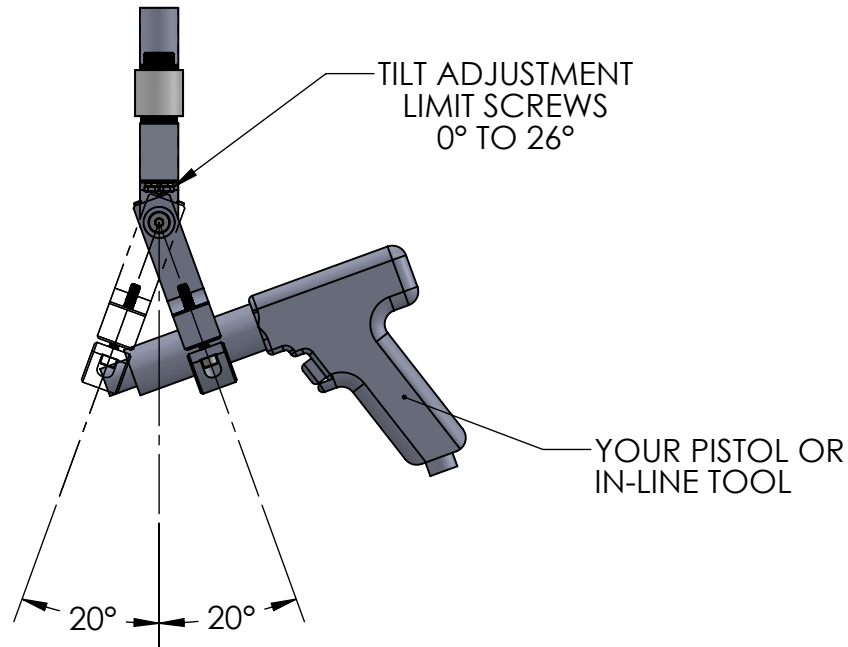
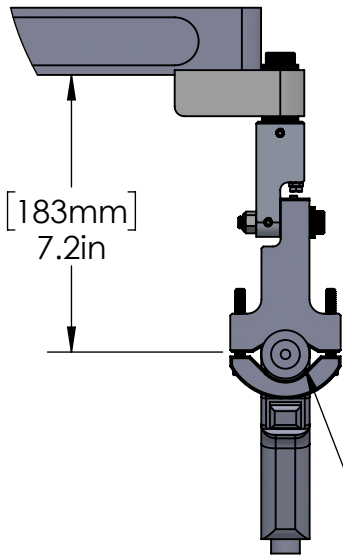
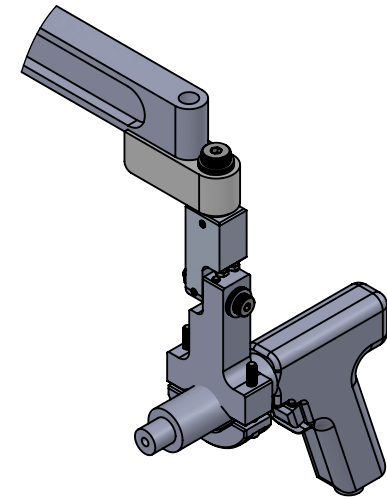
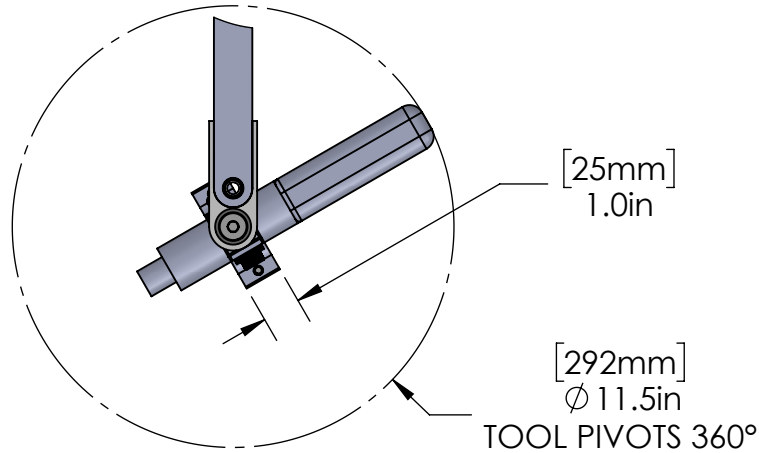

MINIMUM TOOL DIA:
1-1/8" (28.6mm)
MAXIMUM TOOL DIA:
2.0" (50.8mm)

www.toolarms.com

Ergonomic Tool Arms, LLC

MODEL#: PT-TH
PISTOL TILT TOOL HOLDER
FOR HORIZONTAL FASTENING, ALLOWS TILTING ±20°
COPYRIGHT © 2018 ERGONOMIC TOOL ARMS, LLC