

SEE PAGE 2 FOR
TOOL-HOLDER DETAILS

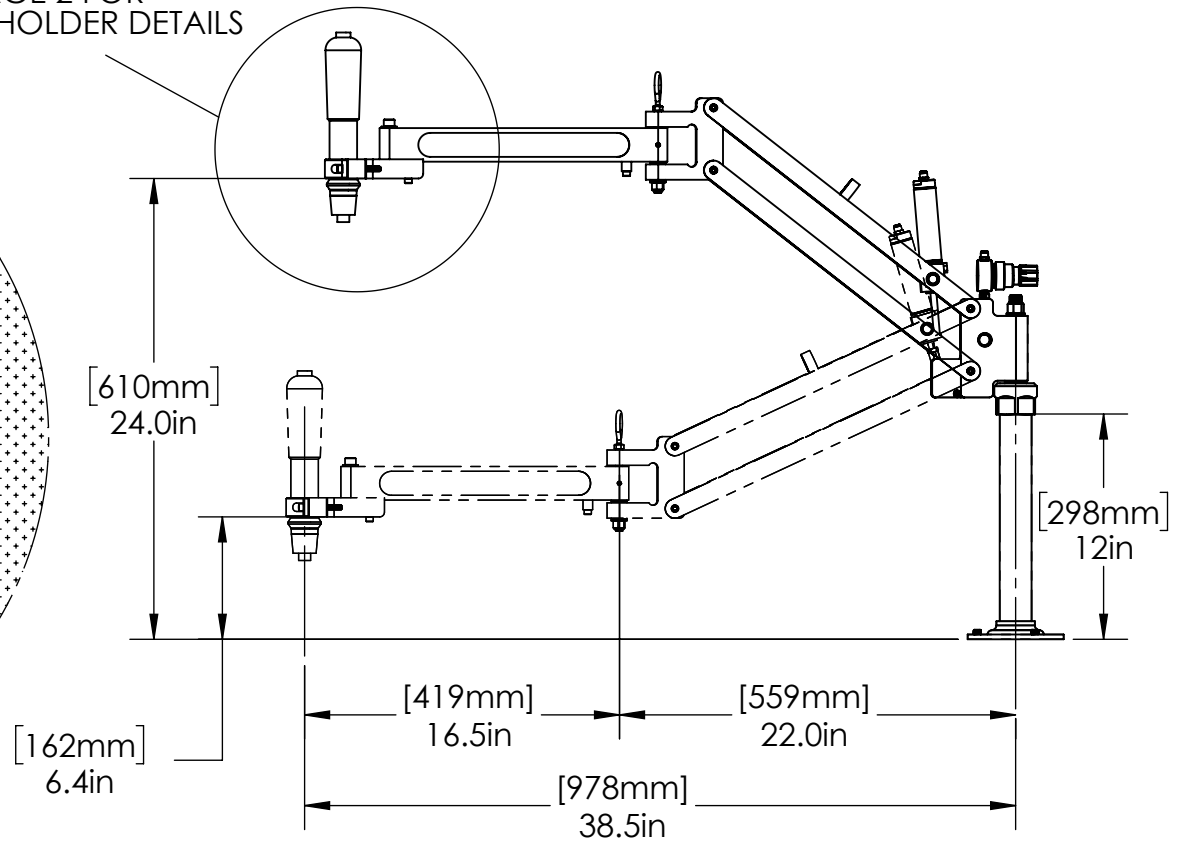

www.toolarms.com



MODEL#: EL506-UV

TOOL HOLDER INCLUDED, UV-TH

For VERTICAL Fastening with customer's In-line
Electric Tool

MAX TORQUE: 550 in-lbs (62 N-m)

MAX. TOOLING WEIGHT: 5 LBS (2.25 KG)

COPYRIGHT © 2018 ERGONOMIC TOOL ARMS, LLC



MINIMUM TOOL DIAMETER:
1-1/8" (28.6mm)
MAXIMUM TOOL DIAMETER:
2.0" (50.8mm)

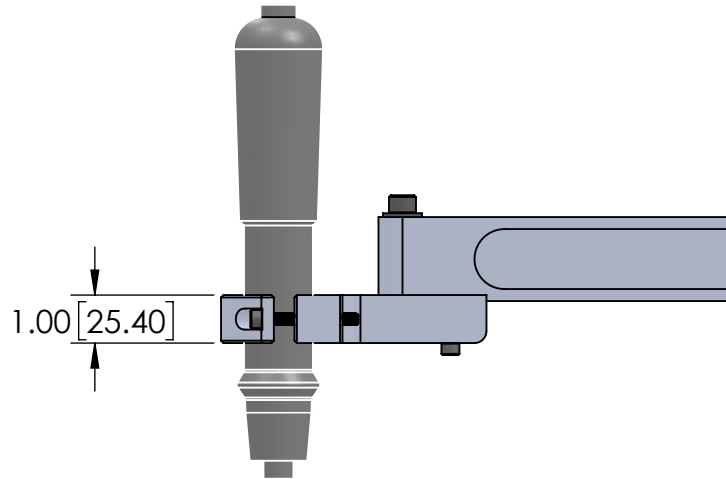
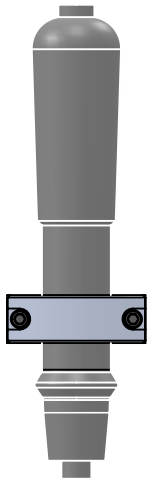
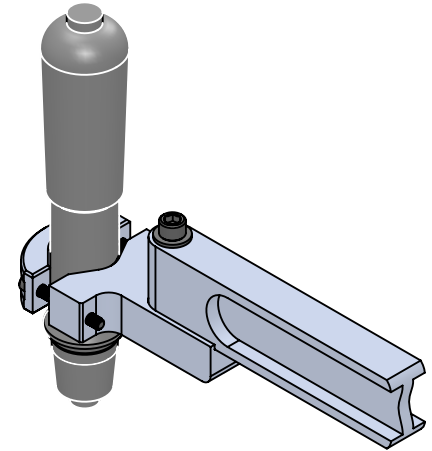
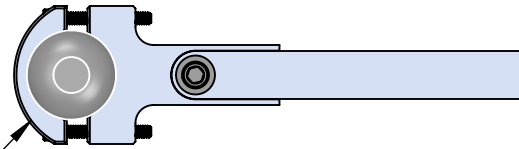

COPYRIGHT © 2017 ERGONOMIC TOOL ARMS, LLC

Model **UV-TH**
Universal Vertical Tool Holder
FOR VERTICAL FASTENING

THIS DRAWING CONTAINS CONFIDENTIAL INFORMATION, IS THE PROPERTY OF ERGONOMIC TOOL ARMS, LLC AND IS GIVEN TO THE RECEIVER IN CONFIDENCE. THE RECEIVER BY RECEPTION AND RETENTION OF THIS DRAWING, ACCEPTS THE DRAWING IN CONFIDENCE AND AGREES THAT IT WILL NOT USE THE DRAWING OR A COPY THEREOF OR THE CONFIDENTIAL INFORMATION IT CONTAINS FOR THE PURPOSES OTHER THAN THAT INSTRUCTED BY ERGONOMIC TOOL ARMS, LLC, EITHER WRITTEN OR IMPLIED. THE RECEIVER AGREES, BY ACCEPTANCE AND RETENTION TO BE HELD LIABLE FOR MISUSE OF THIS DRAWING OR THE INFORMATION IT CONTAINS.