

WORK AREA

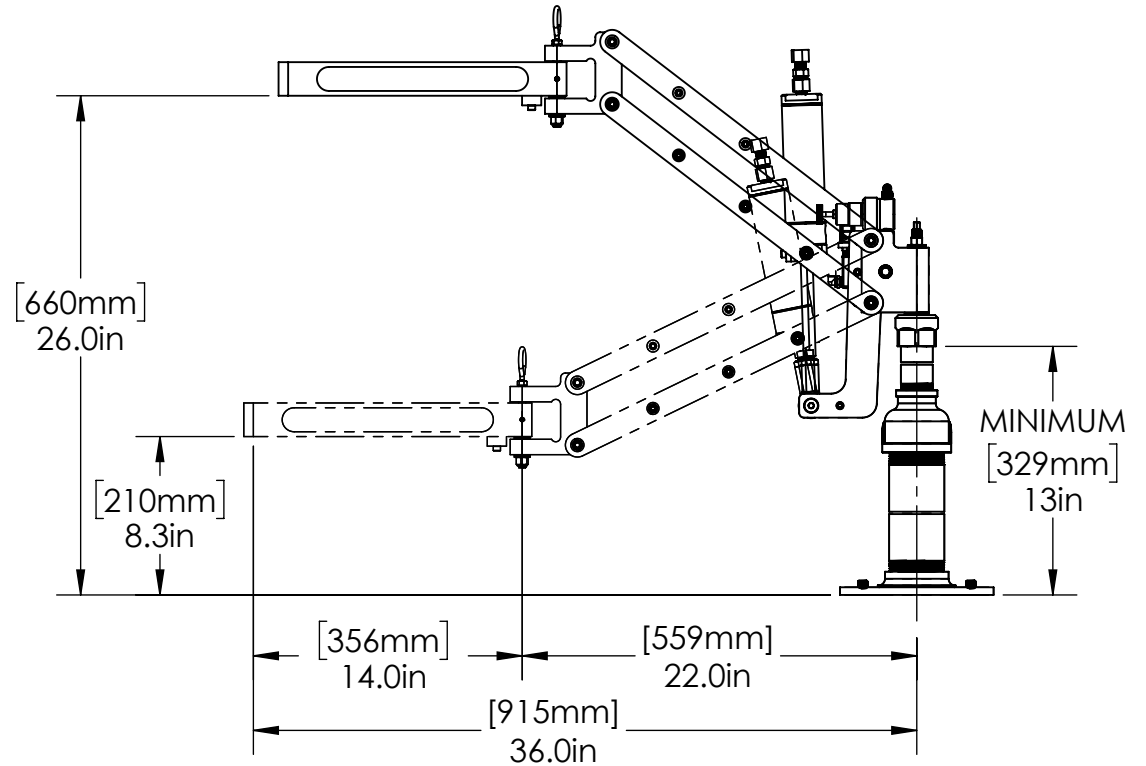
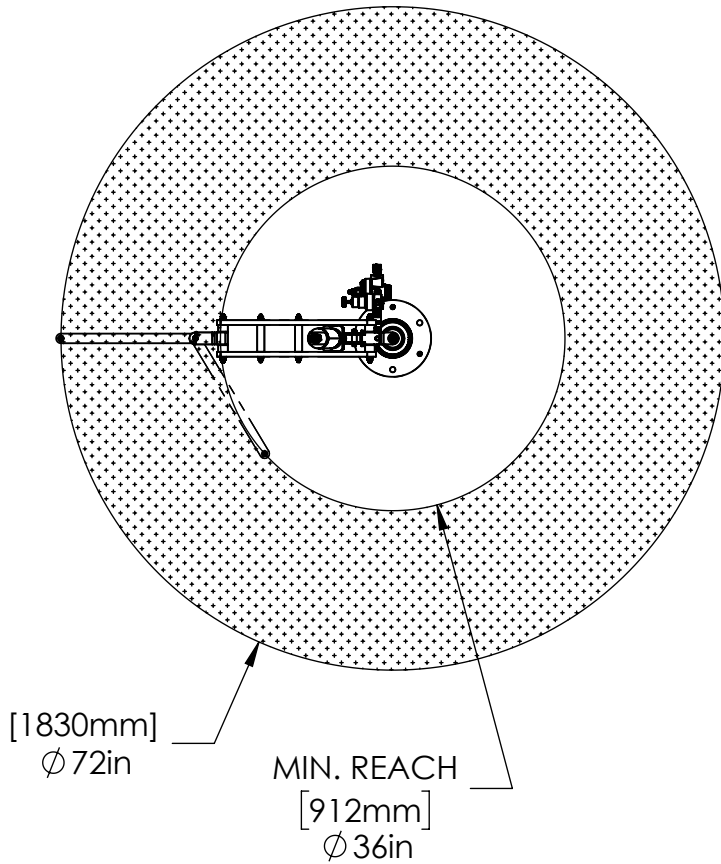

MODEL#: PA1025

Extra Heavy Duty Arm with our highest weight capacity has thick Parallels with cross ties for even more rigidity and a larger diameter Shoulder Pin and Bearings than the 815 frame. Use with customer's Air Tools. Includes B250 Extra Heavy Duty Base Kit. 3/8" ID Tool Supply hose with 3/8" & 1/4" NPT tool connections included.

MAX TORQUE (VERT): 1,100 in-lbs (125 Nm)

MAX TORQUE (HORZ): 600 in-lbs (68 Nm)

MAX. TOOLING WEIGHT: 25 lbs (11.4 kg)

COPYRIGHT © 2018 ERGONOMIC TOOL ARMS, LLC

www.toolarms.com

ETA

Ergonomic Tool Arms, LLC