

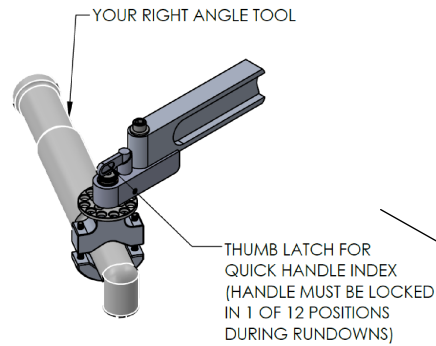

SEE PAGE 2 FOR
TOOL-HOLDER DETAILS

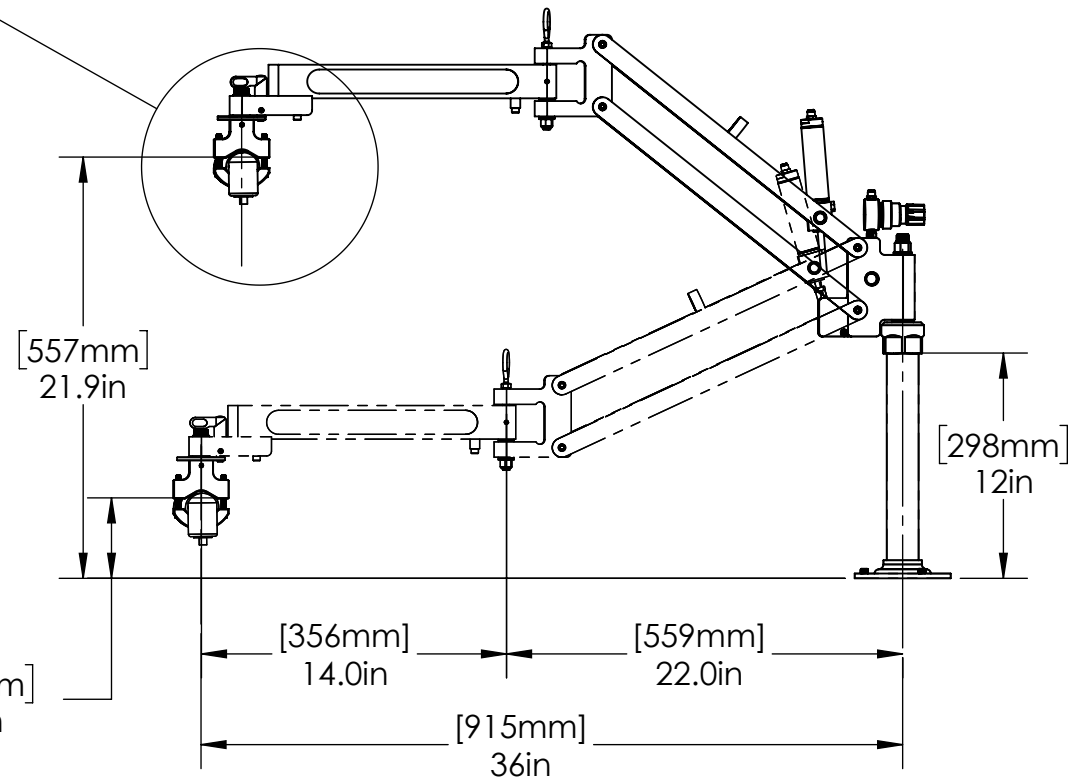

WORK AREA

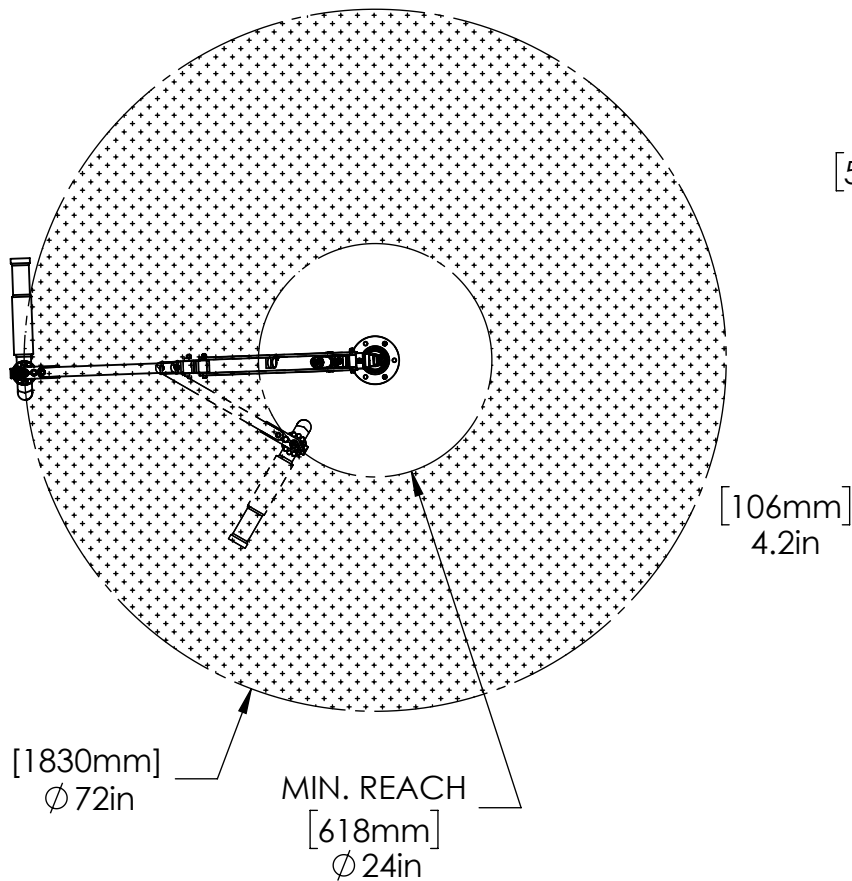

| | |
|--|--|
| <p>www.toolarms.com</p>  <p>Ergonomic Tool Arms, LLC</p> | MODEL#: PA506-RAV |
| | TOOL HOLDER INCLUDED, RAV-TH |
| | For VERTICAL Fastening with customer's Right Angle Air Tool. Has indexable handle positions. |
| | MAX TORQUE: 550 in-lbs (62 N-m) |
| | MAX. TOOLING WEIGHT: 4.5 LBS (2.0 KG) |
| COPYRIGHT © 2018 ERGONOMIC TOOL ARMS, LLC | |

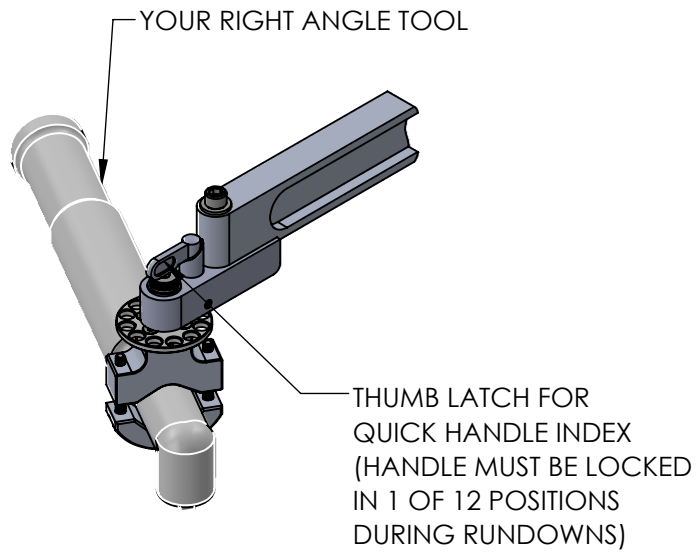

OVERHEAD VIEW

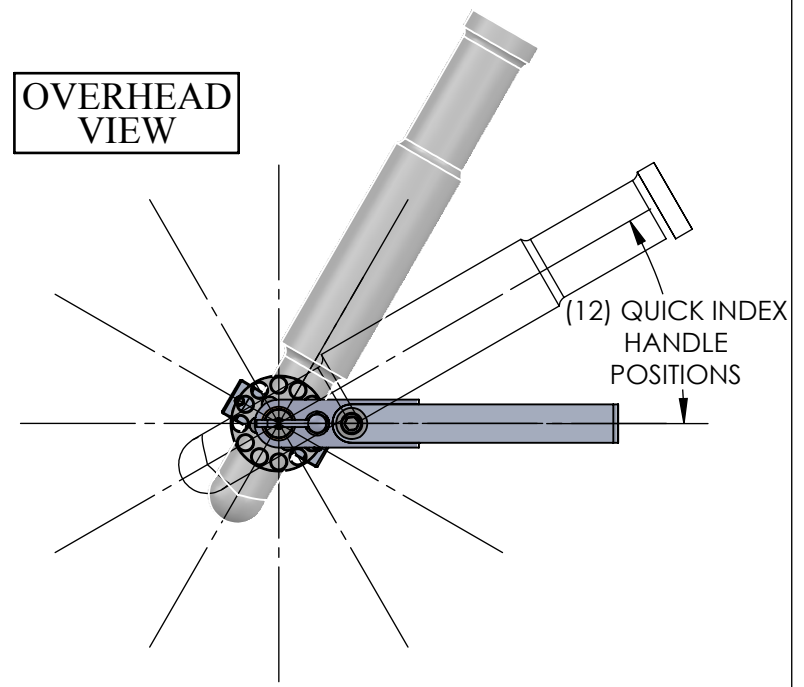

SIDE VIEW

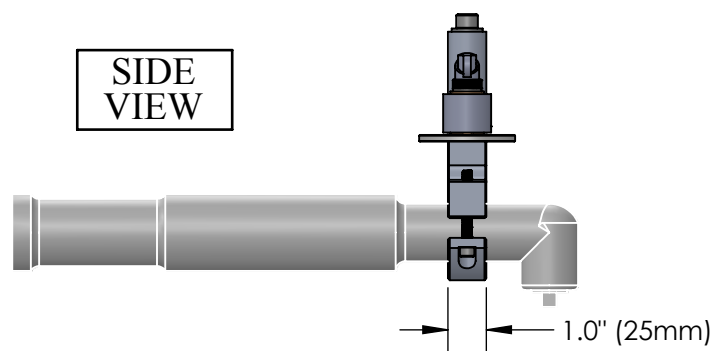

MINIMUM TOOL DIAMETER:
1-1/8" (28.6mm)
MAXIMUM TOOL DIAMETER:
2.0" (50.8mm)

FRONT VIEW

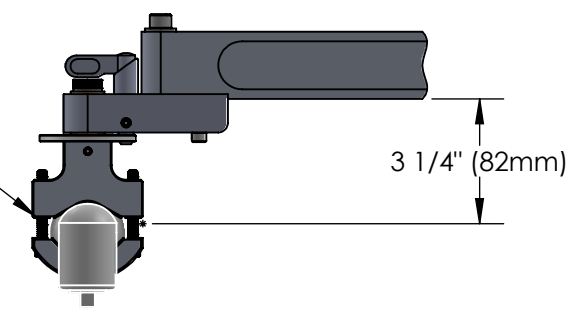

COPYRIGHT © 2017 ERGONOMIC TOOL ARMS, LLC

Model **RAV-TH**
Right Angle Vertical Tool Holder
 FOR VERTICAL FASTENING

THIS DRAWING CONTAINS CONFIDENTIAL INFORMATION, IS THE PROPERTY OF ERGONOMIC TOOL ARMS, LLC AND IS GIVEN TO THE RECEIVER IN CONFIDENCE. THE RECEIVER BY RECEPTION AND RETENTION OF THIS DRAWING, ACCEPTS THE DRAWING IN CONFIDENCE AND AGREES THAT IT WILL NOT USE THE DRAWING OR A COPY THEREOF OR THE CONFIDENTIAL INFORMATION IT CONTAINS FOR THE PURPOSES OTHER THAN THAT INSTRUCTED BY ERGONOMIC TOOL ARMS, LLC, EITHER WRITTEN OR IMPLIED. THE RECEIVER AGREES, BY ACCEPTANCE AND RETENTION TO BE HELD LIABLE FOR MISUSE OF THIS DRAWING OR THE INFORMATION IT CONTAINS.