

SEE PAGE 2 FOR  
TOOL-HOLDER  
DETAILS

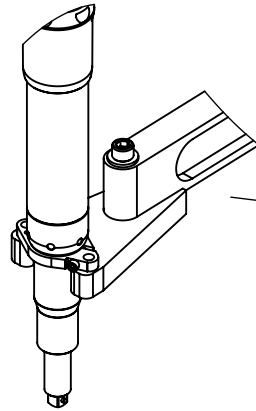

WORK AREA

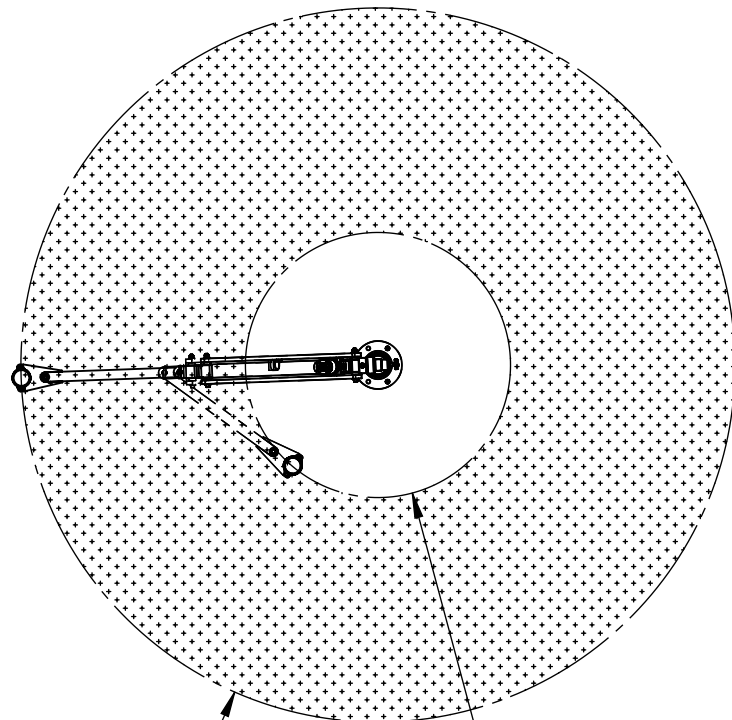

[1956mm]  
Ø 77in

MIN. REACH  
[701mm]  
Ø 28in

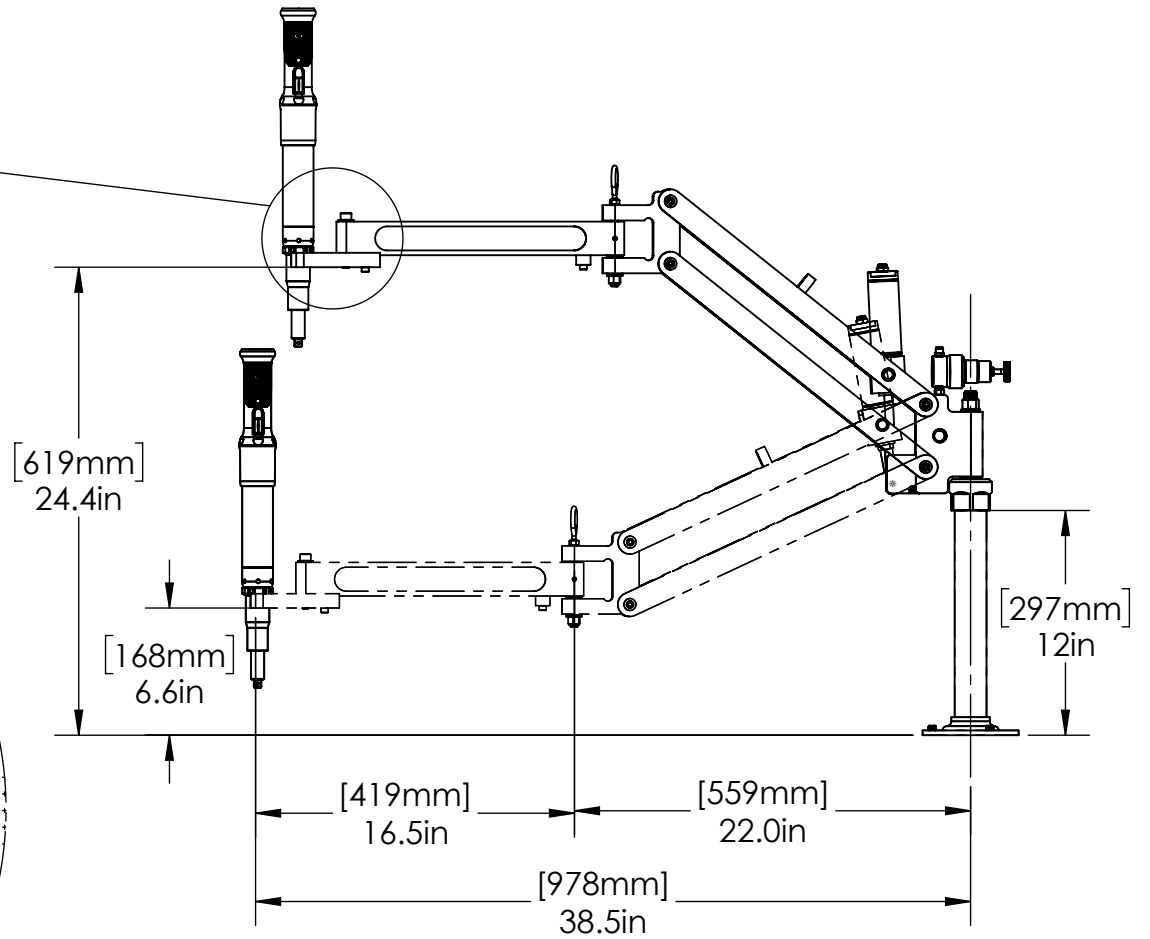

MODEL#: PA815-QA4

TOOL HOLDER INCLUDED, QE4-TH

For VERTICAL Fastening with Ingersoll-Rand QA4  
In-line Flange Mount Air Tools having mounting  
holes 2.19" (55.6mm) on center. 3/8" ID Tool Hose.

MAX TORQUE: 800 in-lbs (90 Nm)

MAX. TOOLING WEIGHT: 14 LBS (6.3 KG)

COPYRIGHT © 2018 ERGONOMIC TOOL ARMS, LLC

www.toolarms.com

**ETA**  
Ergonomic Tool Arms, LLC

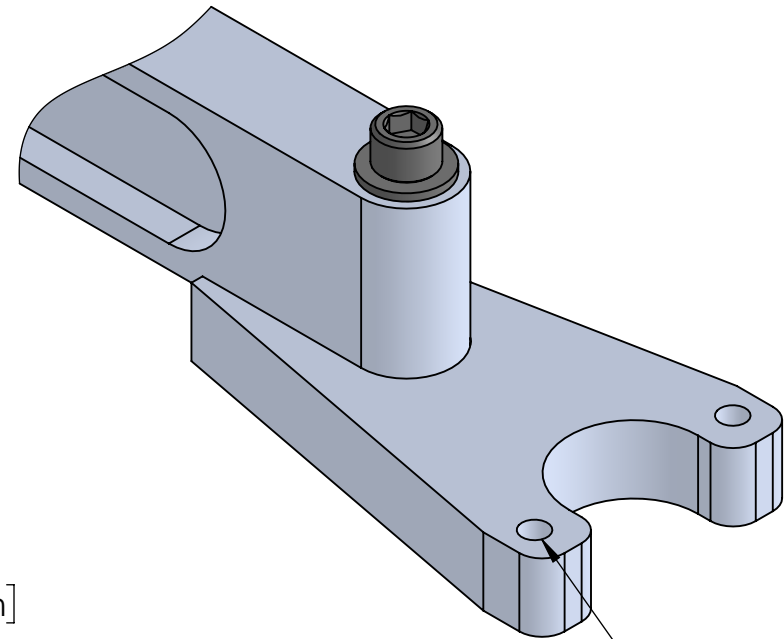
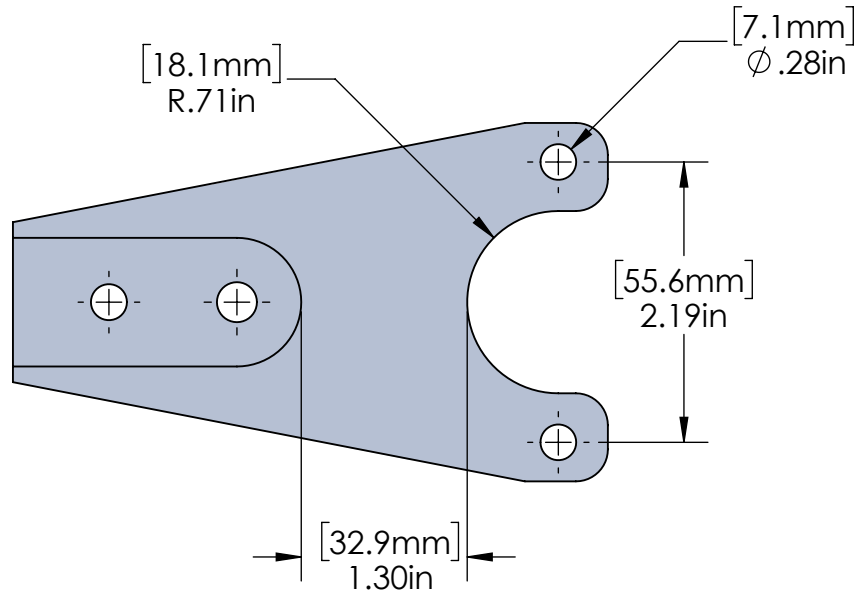

www.toolarms.com



MODEL#: QE4-TH

Vertical Holder for Ingersoll-Rand QE4 In-line tools  
with 2 bolt mounting flange.

COPYRIGHT © 2018 ERGONOMIC TOOL ARMS, LLC