

SEE PAGE 2 FOR
TOOL-HOLDER
DETAILS

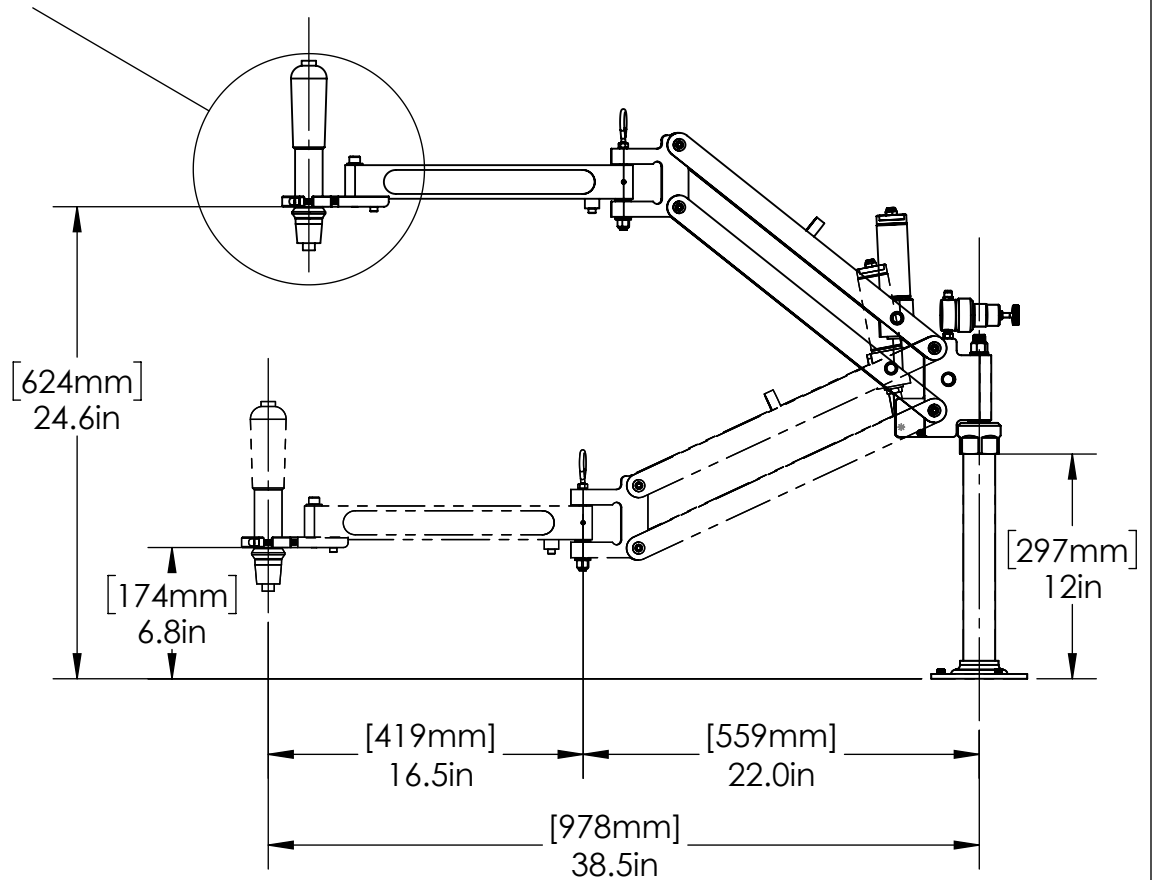
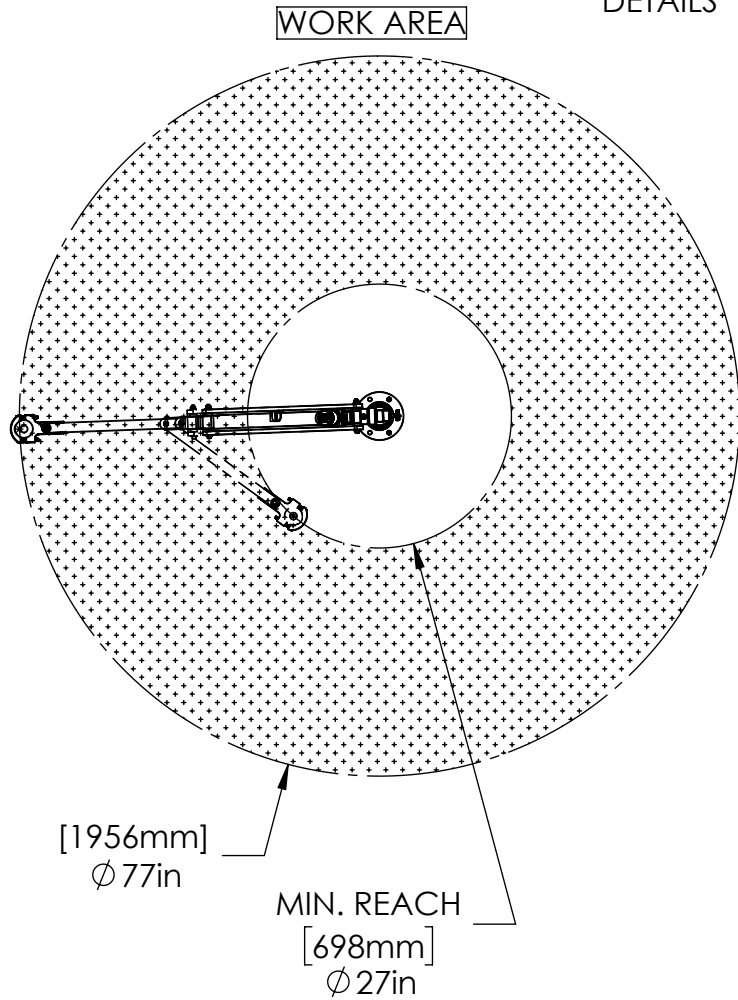

MODEL#: PA815 WITH OPTIONAL TUV-TH

TOOL HOLDER SHOWN, TUV-TH

For VERTICAL Fastening with customer's In-line Air Tool. Includes a Thinner version of our UV-TH for tools with less clamping area.

MAX TORQUE: 800 in-lbs (90 N-m)

MAX. TOOLING WEIGHT: 14 LBS (6.3 KG)

COPYRIGHT © 2018 ERGONOMIC TOOL ARMS, LLC

www.toolarms.com

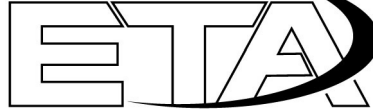

Ergonomic Tool Arms, LLC

www.toolarms.com



MINIMUM TOOL DIAMETER:
1-1/8" (28.6mm)
MAXIMUM TOOL DIAMETER:
2.0" (50.8mm)

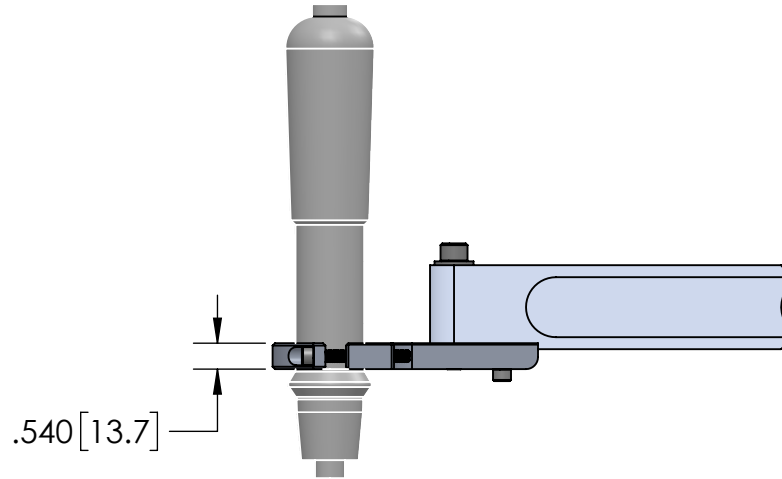
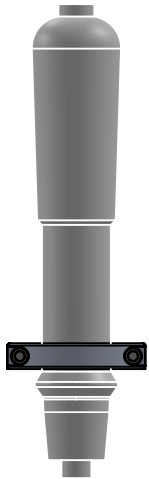
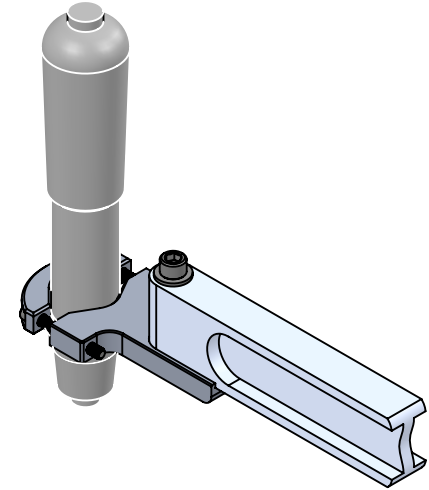
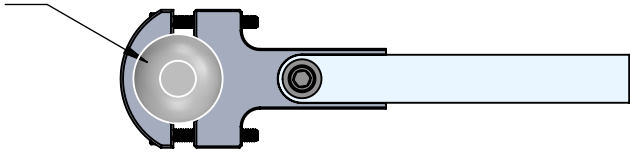

COPYRIGHT © 2017 ERGONOMIC TOOL ARMS, LLC

Model **TUV-TH**
Thin **Universal Vertical Tool Holder**
FOR VERTICAL FASTENING

THIS DRAWING CONTAINS CONFIDENTIAL INFORMATION, IS THE PROPERTY OF ERGONOMIC TOOL ARMS, LLC AND IS GIVEN TO THE RECEIVER IN CONFIDENCE. THE RECEIVER BY RECEPTION AND RETENTION OF THIS DRAWING, ACCEPTS THE DRAWING IN CONFIDENCE AND AGREES THAT IT WILL NOT USE THE DRAWING OR A COPY THEREOF OR THE CONFIDENTIAL INFORMATION IT CONTAINS FOR THE PURPOSES OTHER THAN THAT INSTRUCTED BY ERGONOMIC TOOL ARMS, LLC, EITHER WRITTEN OR IMPLIED. THE RECEIVER AGREES, BY ACCEPTANCE AND RETENTION TO BE HELD LIABLE FOR MISUSE OF THIS DRAWING OR THE INFORMATION IT CONTAINS.